



# Dragonfly Vandal-Proof Dome Camera

## PXD-V40DF

### SPECIFICATION

Main camera	
Power Source	DC +12V
Power Consumption	2W : (not including Supplemental camera&IRIS motor)
Synchronization	Internal
Image Pick-up Device	1/3" color IT CCD (SONY ICX638AK)
Total Pixels	811(H) x 508(V)
Effective Pixels	768(H) x 494(V)
Scanning	Internal
Minimum Illumination	0.5Lux at F1.3
Resolution	520 TV Line
Video Output	1Vp-p composite video 75Ω unbalanced
Scanning Frequency	15.734KHz(H) / 59.94Hz(v)
AGC	ON/OFF selectable
White Balance	ATW / AWB / Manual selectable
BLC function	Independent selectable 64point & weight.
Sharpness	Super High-Resolution
Flickerless	ON / OFF selectable (1/100sec)
Operating Temperature	-10°C to +50°C (14°F~122°F)

Supplemental camera	
Power Source	DC +5V~+12V
Power Consumption	1.5W : (each one camera).
Synchronization	Internal
Image Pick-up Device	1/4" color IT CCD
Total Pixels	811(H) x 508(V) (When High-Resolution camera is selected)
Effective Pixels	768(H) x 494(V) (When High-Resolution camera is selected)
Scanning	Internal
Minimum Illumination	1.0Lux at F1.2
Resolution	480 TV Line (When High-Resolution camera is selected)
Video Output	1Vp-p composite video 75Ω unbalanced
Scanning Frequency	15.734KHz(H) / 59.94Hz(v)
AGC	ON
White Balance	ATW
BLC function	ON / OFF selectable
Flickerless	ON / OFF selectable (1/100sec)
Operating Temperature	-10°C to +50°C (14°F~122°F)

### OSD function images.

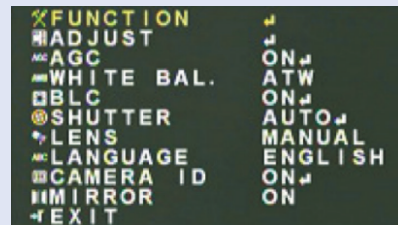

### DIMENSION

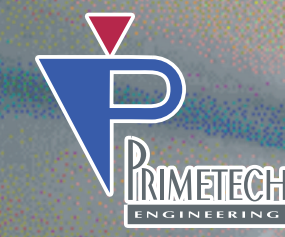
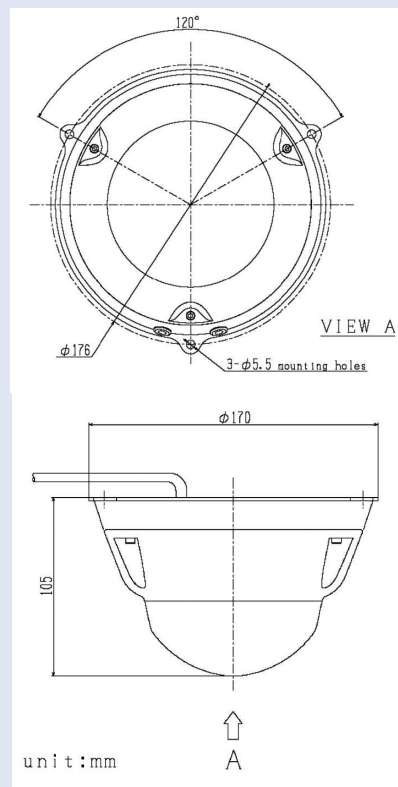

# Dragonfly Vandal-Proof Dome Camera



NEW MODEL

## PXD-V40DF



An innovative concept from Primetech. The conventional dome camera, while shock-resistant, tends to be defenseless from spray-paint or other masking agents. Like the compound eye of a dragonfly, there are four strategically placed cameras (main camera and three supplemental cameras) inside the dome. Even if the main camera is vandalized, the three supplemental cameras will still capture.

**THIS DOME CANNOT BE INCAPACITATED BY PAINT OR MASKING AGENTS!!**

### Features

- Four built-in CCDs
- Vandal-Proof (Dome cover:3mm PC/ IP66)
- Day & Night (IR Cut filter) :optional
- 1/3" SONY ICX638 CCD, 520TVL(main camera)
- On Screen Display (OSD :main camera)
- 7" dome , weight 400g (without cables)

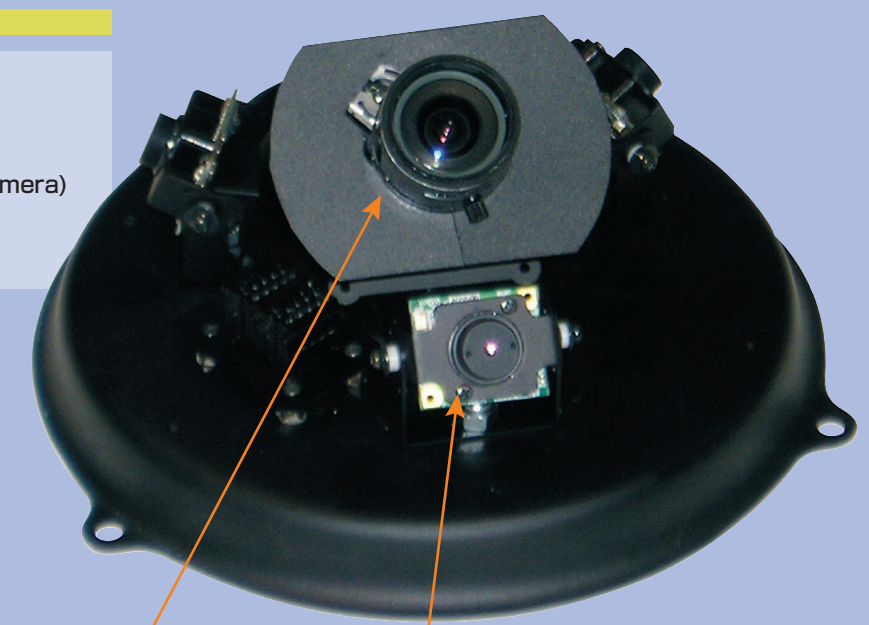

**Supplemental camera**  
\* Wide angle lens & High-Quality color camera.  
\* Available in Standard and High-Resolution.

**Main camera**  
\* Can choose various lenses  
Fixed/Variable Focal Auto Iris/Variable focal day/night.

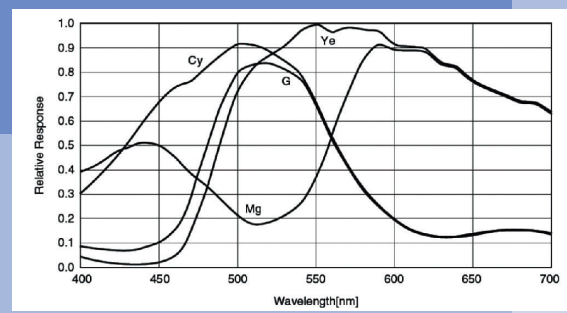

**PRIMETECH ENGINEERING** www.pte.jp  
**PRIMETECH ENGINEERING CORP.**  
 Ts93Bldg, 3F, 4-2-6, Kohinata, Bunkyo-Ku, Tokyo 112-0006, Japan  
 TEL : +81-3-5805-6766  
 FAX : +81-3-5805-6767  
 E-Mail : eigyo@pte.jp

**PRIMETECH ENGINEERING FACTORY OF YOKOHAMA.**  
 Sannomori Town Bldg.2F, 108-7, Sanmaicho, Kanagawa-ku, Yokohama-City, Kanagawa 221-0862, Japan  
 TEL : +81-45-488-6421 FAX : +81-45-413-5144

**PRIMETECH KOREA.**  
 Address (Zip code:463-825):  
 2318 Bobos Chereville Bldg, 5-2 Sunae-dong, Bundang-gu, Seongnam-si, Gyeonggi-do, Korea.  
 TEL : +82-31-719-7223 E-Mail : sdlee@primeview.co.kr

**DISTRIBUTED BY**  
**Ikas, Incorporated**  
 6303 Owensmouth Ave., 10th Fl. Woodland Hills, CA 91367  
 TEL : 1-818-882-4116  
 FAX : 1-818-341-6466  
 E-Mail : sales@ikasinc.com